



Thank you for purchasing a **COMEUP** compact strap hoist. This manual covers operation and maintenance of the compact strap hoist. All information in this publication is based on the latest production information available at the time of printing.

### General Safety Precautions

The compact strap hoist has been designed to give safe and dependable service if operated according to the instructions. Please read and understand this manual before installation and operation of the compact strap hoist.

Follow these general safety precautions:

- Before operating the compact strap hoist, the operator must understand and comply with the requirements of the law concerned.
- Confirm that the hoist complies with the using conditions..
- Keep the compact strap hoist secure strongly.
- Don't use unsuitable pulleys or accessories concerned..
- Don't use unsuitable strap in construction, strength or having any defects.
- Pay attention to the grounding, it provides a path of least resistance for electric current to reduce the risk of shock.
- Check the hoist for smooth operation without load before loading operation





### WARNING

- 1.The compact strap hoist is not to be used to life, support or otherwise transport personnel.
- 2.A minimum of three (3) wraps of strap around the drum is necessary to support the load rated, to ensure the hoist operate safely.
- 3.The owner and/or the operator shall have an understanding of these operating instructions and the warning before operating the compact strap hoist. Failure to follow these warnings may result in loss of load, damage to the hoist, property damage, personal, or fatal injury.
- 4.The owner shall retain this manual for further reference to important warnings, installation, operating and maintenance instructions.
- 5.Hoist operators shall be aware of potential strap break. Please stay away from the working area while operate the hoist, and maintenance regularly.

# I. Installation Precaution

## ► General Safety Precaution

 <b>WARNING</b>	
	The following environmental conditions may result in the possible causes of compact strap hoist trouble

- Low temperature below -10°C, high temperature above 40°C or humidity above 90% conditions.
- ※Cause malfunction of spare parts

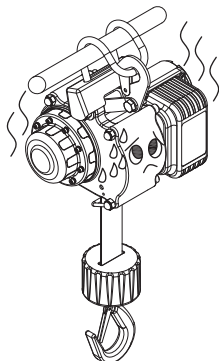

- In an organic chemistry or explosive power conditions.
- ※Cause explosion

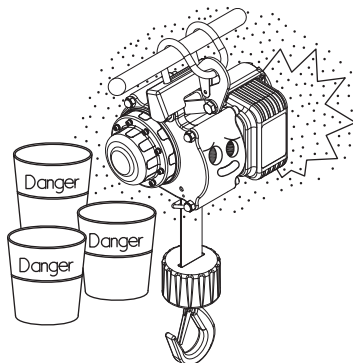

- In the rain or snow
- In heavy acid or salty conditions
- ※Cause rust or short circuit
- ※Cause malfunction of spare parts

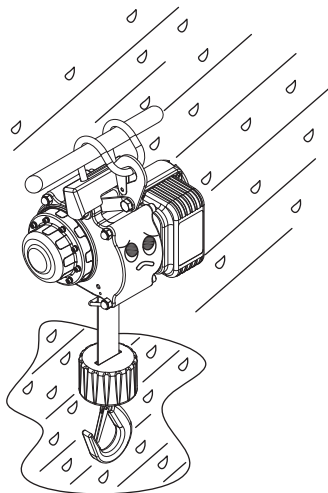

- In a heavy general powder conditions
- ※Cause malfunction of performances

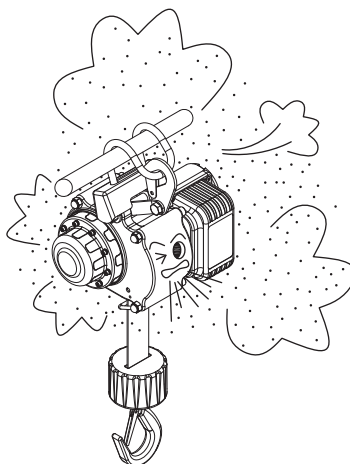

## **II. Handling Precautions**

- \* Only trained personnel can operate the belt crane.
- \* To prevent the risk of electric shock, the power plug must be plugged into a matching outlet and grounded in good condition.
- \* Never try to lift a load higher than the rated cap.
- \* Never hitch a ride on the hook, sling or load being moving
- \* Compact strap hoist are not to be used for lifting or lowering people.
- \* Don't work, walk or stand under an operating hoist.
- \* Always remain in control. Never neglect the chain hoist while actually hosting a load.
- \* Never gravitate a load free.
- \* Be sure to lift a load vertically.
- \* Prior to starting of use, carry out the daily checking without fail, and after confirming the safety of function.
- \* If having a counter rotation incurred, make sure to correct its rotation direction.
- \* Prior to lift. Make sure to have a precise performance of brake. If any malfunction of brake happened, stop the operation immediately.
- \* When load suspended in air, it will not allow to be welding.
- \* Load strap must be kept clean. If they are dirty, they should only be cleaned with a neutral detergent. Do not use organic solvents.
- \* Load strap with any remarkable wears and elongations shall be removed or replaced immediately.
- \* If the gearbox produces harsh noise or severe concussion, stop operating the compact strap hoist immediately.
- \* The operating compact strap hoist must not exceed its intermittent rated time of ED% and the highest number of operation per hour.
- \* Be sure to fix a rope in the center of weight hook.
- \* When operating with a compact strap hoist, do not drag the load laterally.
- \* Before the compact strap hoist is operated, be sure to check the load equally and close to the center to achieve the balance of load.
- \* Avoid splashing water to the motor and control box.
- \* Be sure to have a steady and accurate pendant switch operation and avoid operate excessive inching.

### III. Major Specifications

#### ► Machine Type

Model	CSH-250	CSH-130
Percentage Duty Cycle (%ED)	25% ED, 63% load	
Voltage	AC single phase 100 – 120V	
Rated Load	250 kg	130 kg
Lifting Height	5 m	
Motor	100 – 120 V / 300W, Permanent magnetic motor	100 – 120 V / 300W, Permanent magnetic motor
Speed	5-6 m/min	
Brake	Spring applied drag brake + Disc drag brake + Motor dynamic brake	
Gear ratio	216 : 1	112.7:1
Strap spec	50 mm × 1.2 mm × 5.5 M (breaking strength1,500kg)	
Power lead	2.0 mm <sup>2</sup> × 3C × 3 M	
Pendant switch	emergency stop function pendant switch w/1.25 mm <sup>2</sup> × 6C × 5 M cord	

#### ► Major Dimensions

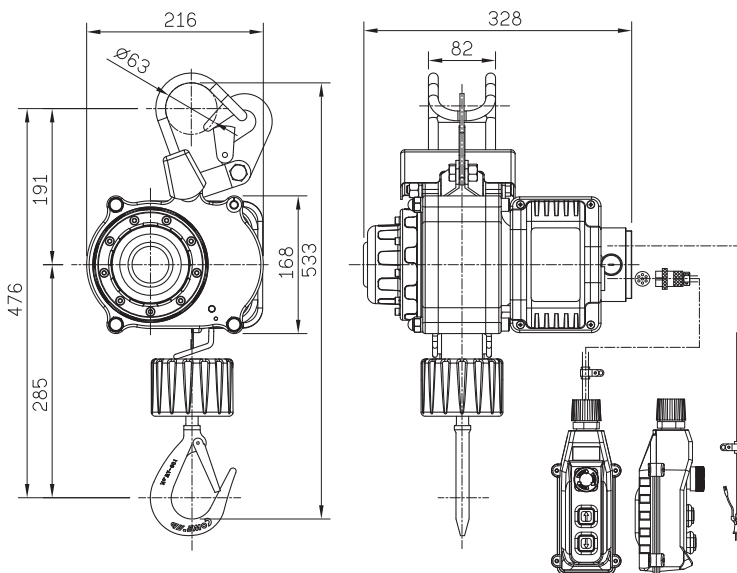

► **Determination of the FEM Classification**

Load Spectrum	State of Loading	Cubic Mean Value	Average Daily Operating Time in hours	Calculated Total Operating Time in hours
Light	Occasional full load; Usually light load; Small fixed load	$k \leq 0.5$	$2 \leq$	3,200
Medium	Occasional full load; Usually light load; Average fixed load	$0.5 < k \leq 0.63$	$1 \leq$	1,600
Heavy	Repetitive full load; Usually average load; Heavy fixed load	$0.63 < k \leq 0.8$	$0.5 \leq$	800
Very Heavy	Usually almost full load; Very heavy fixed load	$0.8 < k \leq 1$	$0.25 \leq$	400

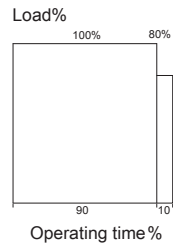
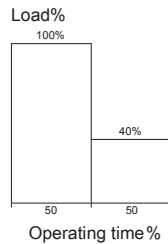
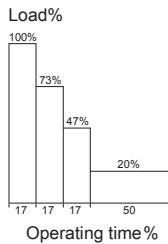
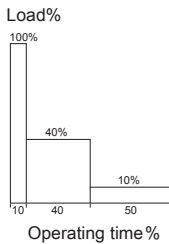

► **Rated Percentage Duty Cycle (%ED)**

The service life of the product is significantly dependent on the frequency at which it is operated. To ensure long service life, operate the winch within its rated percentage duty cycle (%ED). The rated percentage duty cycle (%ED) is expressed by the duty factor (%ED) obtained at the rated voltage and the frequency at 63% of the rated load.

( lifting time + lowering time )

$$\text{Percentage duty cycle (\%ED)} = \frac{\text{( lifting time + lowering time )}}{\text{( lifting time + idle time + lowering time + idle time )}} \times 100 (\%)$$

( Duty Factor )

The maximum startup frequency represents the frequency of startup operations per hours, including inching operations. The rated speed, which indicates the average speed of winding up or down at a rated load. A cycle is limited at 10 minutes at most.

## ► Carrying and installing method

1. Do not install this hoist except those with professional knowledge..
2. The compact strap hoist designed to be hanged or mounted on a firm or stable bar or enough to support the structure of the compact strap hoist and the hanging object.
3. When hanging the compact strap hoist, please hold the handle and lift it up. Hook the hook behind the steel bar and release the hand. And then hook the safety hook to make sure it is correctly hooked before use.
4. When hanging, do not allow the body or load to be caught by any construction of frame, or other obstruction. Be sure to lock the hanger for extra safety..
5. Please use the handle when carrying, it is very convenient.
6. Do not use the safety hook as the load for lifting.

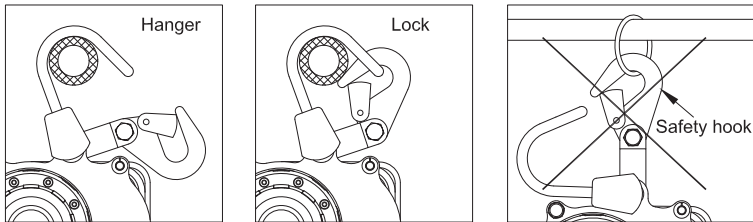

## ► Wiring Diagram

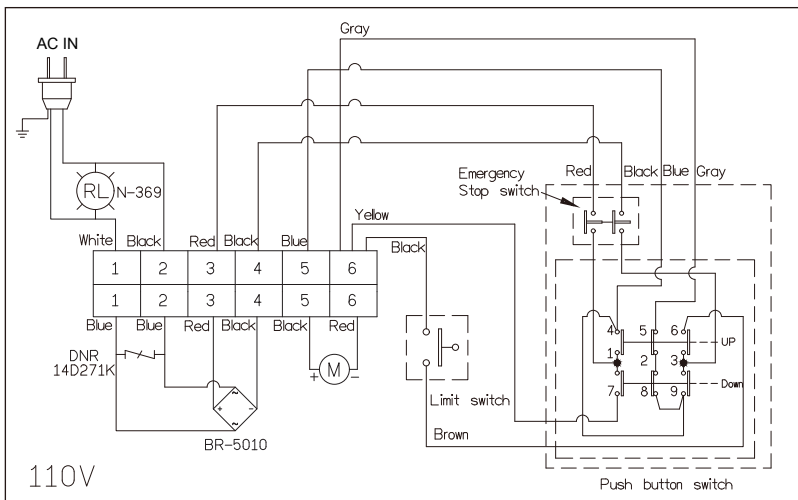

## IV. Working Method

### ► Power Lead and switch cord Sections

The compact strap hoist is supplied with a power lead of 2.0 mm<sup>2</sup> x 3C x 3m power lead. Switch cord is 1.25 mm<sup>2</sup> x 6C x 3 m / 6 m. The power lead and switch cord cannot be longer than 20meter, if the power lead and switch is too long, the voltage will drop, the hoist will not exhibit its rated capacity. Please use a bigger section of power lead or a magnetic contactor as indirect control.

### ► Grounding

To prevent the risk of electric shock, the power plug must be plugged into a matching outlet and grounded in good condition.

### ► Up and Down Switching

To lift a load, press ↑ button and drum will rotate as shown below operation.

To lower a load, press ↓ button and drum will rotate as shown below.

To stop compact strap hoist, release ↑ or ↓ button.

To have an emergency stop function, press the emergency stop. Rotate the button clockwise for returning.

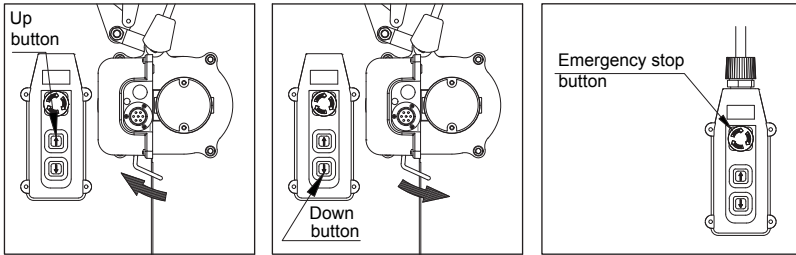

### ► Strap Replacement

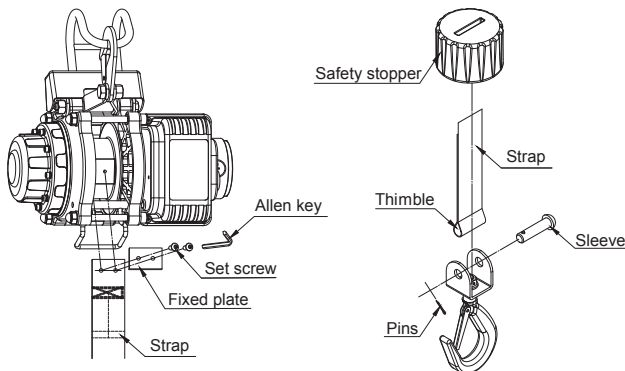

- Put a strap through the hole of the safety stopper.
- Insert a sleeve pin through the thimble of strap.
- Insert a pin through the sleeve pin and bent it by pliers.





## V. Repair, inspection and troubleshooting

### ► Carbon Brush Replacement

 <b>WARNING</b>	
	Clean the accumulated powder of carbon brush periodically to ascertain the insulation resistance up to 1MΩ.

- It is essential to check the carbon brush periodically. If its length is left less than 7.5 mm (original 16.5mm) resulting from wear, it is absolute necessary to replace carbon brush immediately.
- When replacing the carbon brush, both carbon brushes must be replaced at the same time.
- Use standard carbon brushes to ensure the quality and performance of compact strap hoist.

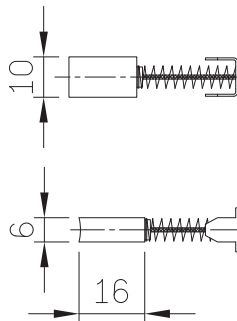
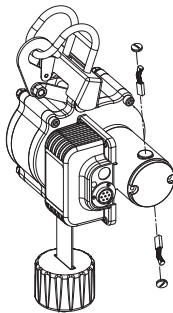

### ► Lubrication

#### ● Gear Box

All the gears are permanently lubricated during assembly. Under normal circumstances, the user does not need to do lubrication again. However, when the gearbox is disassembled for repair or component replacement, please use Castrol Alpha Spherol L-EP 2; Shell Alvania EP2; BP LS-EP2 or the same grade of lubricant for equal replenishment.

#### ● Brake device inspection and replacement

- The brake device uses spring applied drag brake and single rotate brakes. Please check the allowable sliding distance of the brakes within 1.5% of the strap speed before operation. If it is greater than 1.5%, please replace it.

#### ● Over-Winding Lift Prevention

- A special mechanism prevents an over-winding when lifting.
- When the strap stopper touches the limit lever. Lifting is automatically stopped.

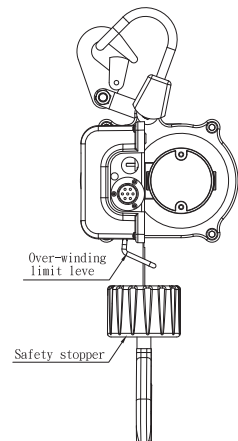

► **Checking**

Classification of checks				Checking Item		Checking Method	Checking Reference
Daily	Periodical						
	One month	Three month	One year				
			☉	Marking	Label and the like	Visual	Existence of label
☉				Compact Strap hoist	Exterior	Visual	No cracks, breaks or significant deformation
☉				Installation	Functional operating mechanisms	Visual	To be properly adjusted and free from unusual sounds when operation
☉				Control/ Switch	Working	Function	Reasonable actuation
☉					Housing	Visual	To be free from cracks
☉					Wiring	Visual	To be free from remarkable loose or damaged
☉					Cord	Visual, electricity	To be free from exposure of conductive wire
	☉			Motor	Condition of insulation	Measure with resistance tester	1MΩmin
☉					Staining damage	Decomposition check	To be free from abnormalities
	☉			Gear	Damage , wearing	Decomposition check	To be free from remarkable wear and damage
		☉			Lubrication condition	Lubricating	Have an abnormal sound to be opened and checked
☉				Load strap	Length stretching	Visual	No significant distortion
☉					winding	Visual	No abnormal entanglement
☉					Surface condition	Visual	No dirt, creases, damage
☉				Load Hook	Housing and mechanical components	Visual, function	To be free cracks, rupture and harmful deformation
☉					Length stretching	Measuring size	deformation by 5% maximum
☉					Safety catch	Visual	To be free from deformed

## ► Trouble Shootings

Before performing any troubleshooting on the compact strap hoist, de-energize the supply of electricity as hazardous voltages are present in the hoist and in connections between components.

Symptom	Possible cause	Remedy
Compact Strap hoist will not operate	Loss of power or wrong voltage/frequency	Check power supply against the rating on the name plate
	Motor burned out	Replace motor
	Improper installation or wearing of carbon brush	Check or replace carbon brush
	Emergency switch button is pressed	Confirm the reason why the emergency switch button is pressed and exclude it
Short circuit	Melted B contact of pendant switch	Replace pendant switch
	Burnt diode	Replace diode and pay attention to its poles
	Having too much carbon powder on carbon brush holder	Disassembly the motor and clean carbon powder
	Burnt motor	Replace motor
Can only lower, or lift	Malfunction of the Up or down contact of the pendant switch	Replace pendant switch
Fail to lift the load rated	Hoist overloaded	Reduce load
	Considerable voltage drop	1 Applied voltage shall fall into $\pm 10\%$ of rated voltage on the name plate 2. The specifications of the power cord are different from the standards.
Brake distance is too long	Brake wear	Please contact an authorized dealer for further repairs.
No brake	Brake failure	Please contact an authorized dealer for further repairs.
Load strap deformation or damage	Strap winding or twisting	Replace strap
	Scratching or impact	Replace strap
Oil leakage	Damaged or deformed oil packing	Replace oil packing
	Fail to install oil packing	Install oil packing

# COMEUP

---

## COMEUP INDUSTRIES INC.

No.139, Jieyukeng Rd., Ruifang Dist., New Taipei City 22453, Taiwan

TEL:+886-2-24971788 FAX:+886-2-24971699

Email: [info@comeup.com.tw](mailto:info@comeup.com.tw)

<http://www.comeupwinch.com>

PN 883583 Ver:02

Specifications subject to change without notice