

COMEUP

Material Handling Hoist



INSTRUCTION MANUAL





Compact Chain Hoist

Limited One (1) Year Warranty Statement

COMEUP Industries Inc. (**COMEUP**) warrants to the original purchaser that the mechanical components and electrical components of the **COMEUP** baby chain hoist will be free of defects in material and workmanship for one (1) year. All **COMEUP** mounting kits and other accessories carry one (1) year limited warranty against defects in material workmanship.

This Warranty applies only to the original purchaser of the chain hoist. To obtain any warranty service, the Purchaser under this Limited Warranty is requested to report **COMEUP** or his authorized distributors of any claims. The Purchaser must provide a copy of the proof of purchase bearing the chain hoist serial number, date of purchase, owners name and address, vehicle details and registration number. Any product **COMEUP** determines to be defective will be repaired or replaced at **COMEUP** sole discretion without charge to Buyer upon Buyer's compliance with these procedures. Seller or its Authorized Distributors may make reasonable charges for parts and labour for repairs not covered by this Limited Warranty.

COMEUP takes the responsibility for all parts and components to be free from defects in materials and workmanship, but the following are hereby excluded and disclaimed:

- (1). All warranties of load chain assemblies after initial use.
- (2). All warranties of fitness for a particular purpose.
- (3). All warranties of the product's finish.
- (4). All warranties of merchantability

The Limited Warranty does not cover any failure that results from improper installation, operation or the Purchaser's modification in design. **COMEUP** reserves the right to change Product design without notice. In situations in which **COMEUP** has changed a product design, **COMEUP** shall have no obligation to upgrade or otherwise modify previously manufactured products.

Thank you for purchasing a **COMEUP** Chain Hoist. This manual covers operation and maintenance of the chain hoist. All information in this publication is based on the latest production information available at the time of printing.

General Safety Precautions

A **COMEUP** chain hoist is designed to give safe and dependable service if operated according to the instructions. Read and understand this manual before installation and operation of the chain hoist.

Follow these general safety precautions:



- Before operating the chain hoist, the operator must understand and comply with the requirements of the law concerned.
- Confirm that the winch complies with the using conditions.
- Keep the chain hoist secure strongly.
- Don't use unsuitable load chain, weight hook or pulleys concerned.
- Don't use unsuitable load chain in grade, strength or having any defects.
- Pay attention to the grounding, it provides a path of least resistance for electric current to reduce the risk of shock.
- Check the winch for smooth operation without load before loading operation.

**WARNING**

1. The chain hoist is not to be used to lift, support or otherwise transport personnel.
2. The owner and/or the operator shall have an understanding of these operating instructions and the warning before operating the electrical chain hoist. Failure to follow these warnings may result in loss of load, damage to the chain hoist, load chain damage, personal, or fatal injury.
3. The owner shall retain this manual for further reference to important warnings, installation, operating and maintenance instructions.
4. Hoist operators shall be trained to be aware of potential malfunctions of the equipment that require adjustment or repair, and to be instructed to stop operation.
5. Hoist operators shall be trained in proper rigging procedures for the attachment of load to the hoist hook

I. Installation Precaution

► General Safety Precaution

 Danger	
	The following environmental conditions may result in the possible causes of which trouble.

- Low temperature below -10°C, high temperature above 40°C or humidity above 90% conditions.
- ※Cause malfunction of spare parts

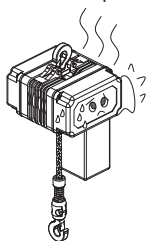

- In an organic chemistry or explosive power conditions.
- ※Cause explosion

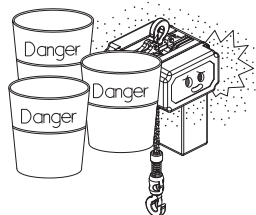

- In the rain or snow
- In heavy acid or salty conditions
- ※Cause rust or short circuit
- ※Cause malfunction of spare parts

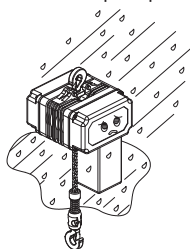

- In a heavy general powder conditions
- ※Cause malfunction of performances

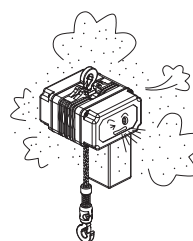

► Power Cut-Off Switch Precaution and Mechanical Torque Limit Device

1. It will be available to equip with a devices of automatic power cut-ff switch which can be installed below the hoist housing. It alerts Red and cuts off the power if over-load or abnormal matter found , please stop the operation immediately for further checking.
2. If it alerts Red and cuts off the power during operating, lower the load, remove the load and stop the operation immediately for further checking. Please reset the switch by hand,
3. The hoist is equipped with an up and down mechanical torque limit device, it activates when over-riding or reversing operation found. It does not allow to activate for more than 6 seconds, otherwise it may damage the hoist endurance.

II. Handling Precautions

- * To prevent the risk of electric shock, the power plug must be plugged into a matching outlet and grounded in good condition.
- * Never try to lift a load higher than the rated cap.
- * Never hitch a ride on the hook, sling or load being moving.
- * Chain hoist is not to be used for lifting or lowering people.
- * Don't work, walk or stand under an operating chain hoist.
- * Always remain in control. Never neglect the chain hoist while actually hosting a load.
- * While working, never stand under a lifting load or within the conveying area.
- * Always look up when working around chain hoist, there is potential danger overhead.
- * Never gravitate a load free.
- * Be sure to lift a load vertically..
- * Prior to starting of use, carry out the daily checking without fail, and after confirming the safety of function.
- * If having a counter rotation incurred, make sure to correct its rotation direction.
- * Prior to lift. Make sure to have a precise performance of brake. If any malfunction of brake happened, stop the operation immediately.
- * When load suspended in air, it will not allow to be welding.
- * Load chain with any remarkable wears and elongations shall be removed or replaced immediately.
- * Stop the operation if there is any queer noise or vibration in the gear box to be happened.
- * Do not connect the load chain with the grounding of welding machine.
- * While welding, do not have any contact with the welding objects because of having spark.
- * Do not pull the switch.
- * Do not over the rated intermittent period.
- * Do not operate beyond the limits of the load chain travel
- * Be sure to fix a load chain in the center of load hook.
- * Be sure to stop operation immediately when the load chain becomes fully slackened.
- * Avoid catching the hook or lifting a load on a fixed obstruction.
- * Always leave the pendant switch positioned immediately after use.
- * Make sure that the load being lifting is well balanced and secured before starting.
- * Avoid water splashes on the pendant switch and electrical circuits.
- * Never wrap the load with the load chain.
- * A power cut-off switch located below the house cuts off the power, please stop the hoisting immediately. Please reset the switch by hand after reducing a load by manual ◦
- * The hoist is equipped an up mechanical torque limit device, it activates when over-riding operation found. It does not allow to activate for more than 6 seconds, otherwise it may damage the hoist endurance.

III. Major Specifications

► Machine Type and Major Dimensions

Model	CK-500		CK-1000	
Power Supply	Single-phase, 100 – 120V, 200 - 240V AC, 50/60 Hz			
Type of Fall	Single		Double	
Rated Load	500 kg		1,000 kg	
Lifting Height	3 m	6 m	3 m	6 m
Line Speed	6.5 m/min		3.2 m/min	
Percentage Duty Cycle (%ED)	25% ED with a maximum of 60 starts per hour			
Drive Group	FEM: 9,511 1Bm, ISO: 4301-1 M3			
Motor	100-120V	750 w, 9.5A permanent magnetic		
	200-240V	750 w, 4.5A permanent magnetic		
Control System	Direct control with an emergency stop function pendant switch			
Power Lead	1.5 mm ² x 3C x 3 m w/industrial plug			
Control cord	1.25 mm ² x 5C x 3 m / 1.25 mm ² x 5C x 6 m			
Brake	Double brakes of mechanical ratchet pawls and a motor dynamic brake provide failsafe brake			
Gear Ratio	70.2 :1			
Load Chain	Grade	Grade 80 – Links 6.3 mm dia x 19 mm long		
	Length	3.5 m		6.5 m

CK-500

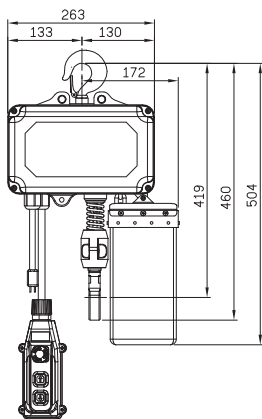

CK-1000

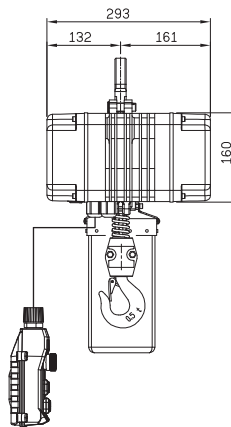
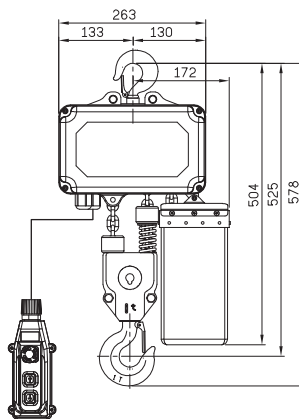

► **Determination of the FEM Classification**

Load Spectrum	State of Loading	Cubic Mean Value	Average Daily Operating Time in hours	Calculated Total Operating Time in hours
Light	Occasional full load; Usually light load; Small fixed load	$k \leq 0.5$	$2 \leq$	3,200
Medium	Occasional full load; Usually light load; Average fixed load	$0.5 < k \leq 0.63$	$1 \leq$	1,600
Heavy	Repetitive full load; Usually average load; Heavy fixed load	$0.63 < k \leq 0.8$	$0.5 \leq$	800
Very Heavy	Usually almost full load; Very heavy fixed load	$0.8 < k \leq 1$	$0.25 \leq$	400

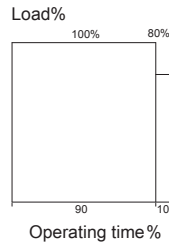
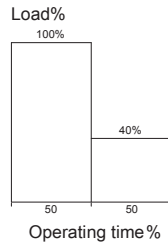
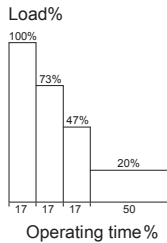
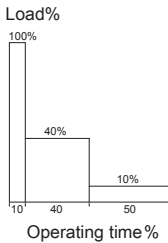

► **Rated Percentage Duty Cycle (%ED)**

⚠ WARNING	
⊘	Do not exceed the rated intermittent period.

The service life of the product is significantly dependent on the frequency at which it is operated. To ensure long service life, operate the winch within its rated percentage duty cycle (%ED). The rated percentage duty cycle (%ED) is expressed by the duty factor (%ED) obtained at the rated voltage and the frequency at 63% of the rated load.

$$\text{Duty Factor (\%ED)} = \frac{\text{(lifting time + lowering time)}}{\text{(lifting time + idle time + lowering time + idle time)}} \times 100 (\%)$$

Percentage duty cycle (%ED) = ----- X 100 (%)
(Duty Factor)

The maximum startup frequency represents the frequency of startup operations per hours, including inching operations. The rated speed, which indicates the average speed of winding up or down at a rated load. A cycle is limited at 10 minutes at most.

► Safety Devices

1). Dual braking system

The hoist is equipped with a permanent magnet motor, when a power off, DC-current electromagnetic brake will activate the braking immediately ◦ Furthermore ratchet pawl brake also provides instant and safe braking without slippage.

2). Torque limiter

A torque limiter is an automatic device that protects mechanical equipment, or its work, from damage by mechanical overload or over-travel. A torque activates when the load exceeds 130% of rated load. The limiter limits the torque by slipping as in a friction plate slip-clutch.

3). Power cut off switch

It incorporates a circuit breaker that protects the devices from a power overload or an over-winding of load chain. The fuse will blow out around 2 seconds after an over-winding. When the switch cuts off the power, stop the hoisting operation immediately and turn off or unplug electrical device. After taking a rest of the motor cooling or reducing the load, reset the switch located below the housing by manual.

4). Emergency stop switch

A pendant switch with an emergency stop button cuts the power source for safety.

► Wiring Diagram

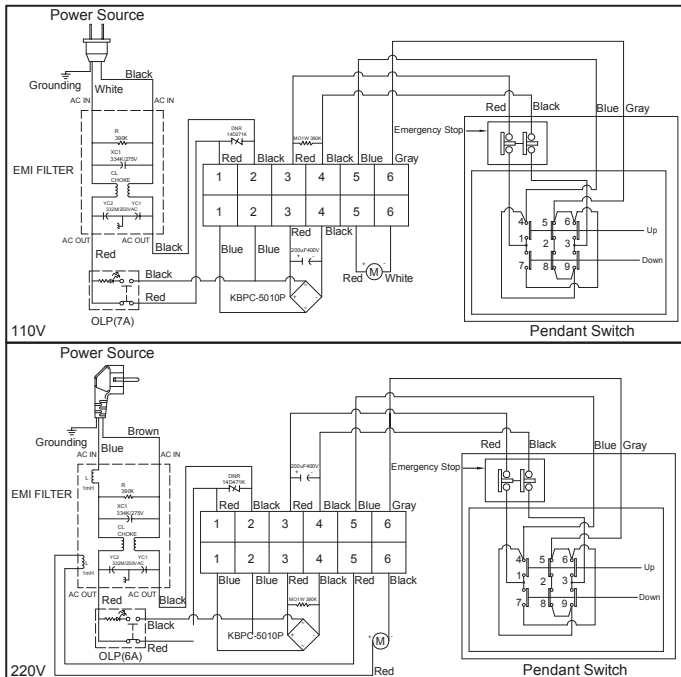

IV. Working Method

► Power Lead Sections

The machine is supplied with a power lead of 1.5 mm² x 3 m for 200 – 240V or 2.0 mm² x 3C x 3 m for 100 – 120V power source. If the power lead is too long or thin, or if it is branched to supply other power loads, the voltage will drop and the hoist will not exhibit its rated capacity, possible resulting in failure. For any other cases, please use a bigger section of power lead or a magnetic control box to prevent a considerable voltage drop to be happened.

► Grounding

To prevent the risk of electric shock, the power plug must be plugged into a matching outlet and grounded in good condition.

► Up and Down Switching

To lift a load, press ↑ button and drum will rotate as shown below operation.

To lower a load, press ↓ button and drum will rotate as shown below.

To stop chain hoisting, release ↑ or ↓ button.

To have an emergency stop function, press the emergency stop.

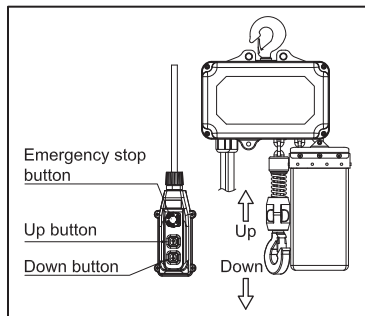

► Load Chain Replacement

- 1). Be sure that the replacement chain is the exact size, grade and constructions as the original chain. The new load chain must have an odd number links so that both its end links have the same orientation. Destroy the old chain to prevent its reuse.
- 2). When replacing load chain, check for wear on mating parts such as sprocket, and replace parts if necessary.
- 3). Remove all chain components including bottom hook kit from the old chain for reuse on new chain. Inspect and replace any damaged or worn parts.
- 4). Single fall operation - Using a C-link to attach the new chain to the old end link on the no-load side. The new end link should be connected so the welded portion to pass over the sprocket.
- 5). Double fall operation – Feed the end link on the load side of the new chain through the require chain components and idle sheave of load hook. Attach the remaining chain components to the chain guide rail for the proper locations.

- 6). Operate the hoist down to move the chain through the hoist body. Stop when a sufficient amount of new chain is accumulated on the load side.

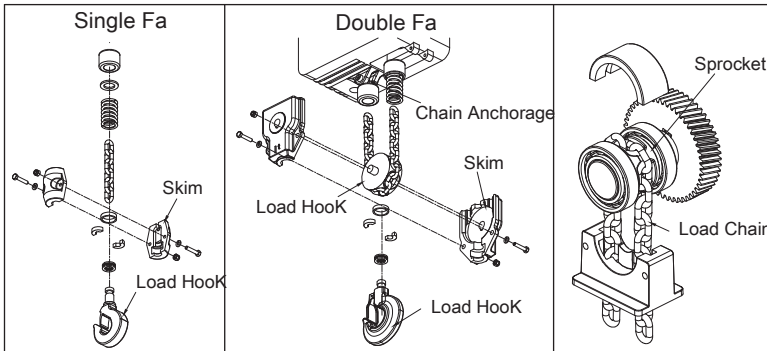

► Carbon Brush Replacement

 <b style="font-size: 1.2em;">WARNING	
	Clean the accumulated powder of carbon brush periodically to ascertain the insulation resistance up to 1MΩ.

- It is essential to check the carbon brush periodically. If its length is left less than 7.5 mm resulting from wear, it is absolute necessary to replace carbon brush immediately.
- While replacing, smoothly insert carbon brush into carbon holder in the first place, then put brush cap into the hole.
- Before tightening the carbon brush holder, make sure to position the O-ring.
- A set of carbon brush consists 2 piece of carbon brush. Ascertain to replace 2 pieces of carbon brush on opposite sides of chain hoist body at the.

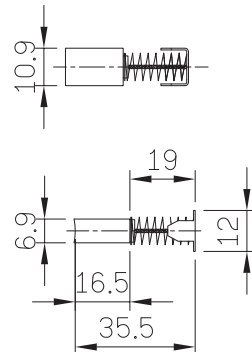
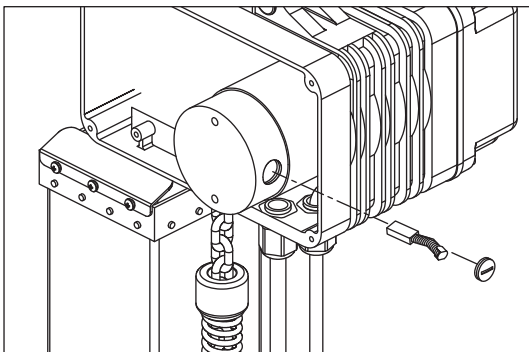

► Braking Adjustment

- Braking device is design by double mechanic ratchet pawls to provide instant and safe operation.
The brake distance from the time of braking until stopping completely should be within 1.5% of load chain length to the wound in during 1 minute.
- Owing to the load chain speed on no load is 1.3 times faster than that on rated load, the brake distance on no load will be longer, but still within 1.5% of load chain length.
- It is highly recommended that any adjustments are carried out by a qualified technician at an authorized service centre.
- Brake adjustment procedures.
Step1. Remove an R-type retaining ring from 2nd pinion and also fix plate, then remove torque limiter kit clockwise
Step2. Take away an old ratchet and replace it by a new ratchet
Step3. Tighten the torque limiter kit counter-clockwise and find the closed 2 parallel pin, then assembly the fix plate.
Step4. Lock the fix plate on the 2nd pinion by an R-type retaining ring.

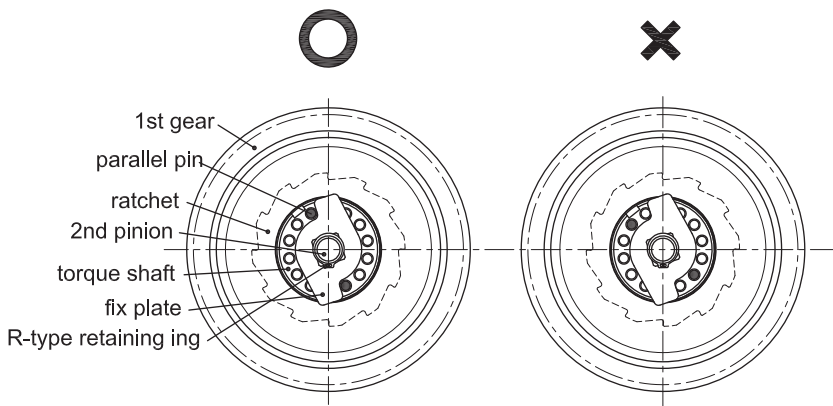

► Torque Limiter Adjustment

It is highly recommended that any adjustments are carried out by a qualified technician at an authorized service centre.

- Torque limiter adjustment procedures
Step1. Remove an R-type retaining ring from 2nd pinion and also fix plate, then remove torque limiter kit clockwise
Step2. Take away an old ratchet and replace it by a new ratchet
Step3. Tighten the torque limiter kit counter-clockwise and find the closed 2 parallel pin, then assembly the fix plate.
Step4. Lock the fix plate on the 2nd pinion by an R-type retaining ring.

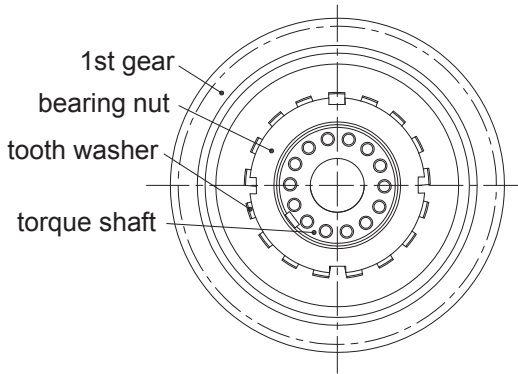

► Oil Replacement

Gear lubrication is an important component in insuring the long service life of your chain hoist. The type of lubricant will have a great influence. Chain hoist are pre-lubricated at the factory and do not require initial lubrication. Re-lubrication interval depends upon service. Consult your local lubricant distributor on the selection that best fits your climate and application.

- Load Chain:

- * For longer life, the load chain should be lubricated with ISO VG 220 or equivalent extreme-pressure (EP) lubricating oil.
- * The chain should be lubricated every week for normal usage. Clean and lubricate more frequently for heavier usage or severe conditions.

- Hook and Suspension Components:

- * Hooks and suspension components should be cleaned and lubricated ISO VG 220 or equivalent extreme-pressure (EP) lubricating oil at least twice per year for normal usage. Clean and lubricate more frequently for heavier usage or severe conditions.

- Gear box:

- * Using incorrect type/grade of gearbox oil or the wrong quantity of oil may prevent the winch from working properly and may affect the ability of the hoist to hold the load.
- * Gear box should be cleaned and lubricated with ISO VG460 synthetic gear lube for 100 working hours for an initial lubrication and at least once per three months for normal usage. It requires 250 CC oil in quantity for every time changing.
- * The oil should be changed more frequently depending on the hoist's usage and operating environment.
- * Dispose of the used oil in accordance with local regulations.

V. Checking and Trouble Shooting

► Checking Reference

Classification of checks				Checking Item	Checking Method	Checking Reference	
Daily	Periodical						
	One month	Three month	One year				
			◎	Marking	Label and the like	Visual	Existence of label
		◎		Installation	Functional operating mechanisms	Visual	To be properly adjusted and free from unusual sounds when operation
◎				Control/ Switch	Working	Function	Reasonable actuation
◎					Housing	Visual	To be free from cracks
◎					Wiring	Visual	To be free from remarkable loose or damaged
◎					Cord	Visual, electricity	To be free from exposure of conductive wire
	◎			Motor	Condition of insulation	Measure with resistance tester	1MΩ min
◎					Staining damage	Decomposition check	To be free from abnormalities
		◎		Braking	Wearing of brake disc	Decomposition check	To be free from remarkable wear and damage
◎	◎				Performance	Visual	Distance to be not more than 1.5% of the lifting speed
	◎			Gear	Damage , wearing	Decomposition check	To be free from remarkable wear and damage
		◎			Lubrication condition	Lubricating	At least once per three months or 100 working hours for normal usage
◎				Load Chain	elongation of link length	Measure	5% minimum
◎					Decreasing of link diameter	Measure	8% of normal diameter max
◎					Kink phenomena run-out of foundation	Visual	To be free from kink phenomena
◎					Deforming or corrosion	Visual	To be free from abnormality
◎					Lubrication condition	Lubricating	The chain should be lubricated every week for normal usage
◎					Surface condition	Visual	To be free from rust, nicks, gouges, dents and weld splatter.
		◎		Sprocket / Idle Sheave	Reeving	function	Chain should be reeved properly through sprocket and idle sheave for double fall operation
◎				Frame	Housing and mechanical components	Visual, function	To be free cracks, rupture harmful deformation
◎				Load Hook	Housing and mechanical components	Visual, function	To be free cracks, rupture and harmful deformation by 5% maximum
◎					latch	Visual	To be free from deformed

► Trouble Shootings

Before performing any troubleshooting on the chain hoist, de-energize the supply of electricity as hazardous voltages are present in the hoist and in connections between components.

Symptom	Possible cause	Remedy
Hoist will not operate	Loss of power or wrong voltage/frequency	Check power supply against the rating on the name plate
	Power cutoff switch cuts off the power	Reduce load to within rated capacity of hoist and reset by manual
	Motor overheated	Take a rest and perform the hoist according to its duty cycle percentage rated at 25%ED
	Motor burned out	Replace motor
	Brake does not release	Check or replace brake assembly
	Improper installation or wearing of carbon brush	Check or replace carbon brush
	Escape or open circuit of carbon brush lead	Check or replace carbon brush lead
Can lift, but fail to lower	Down circuit open	Check down limit switch for malfunction
	Malfunction of the Down contact of the pendant switch	Replace pendant switch
Can lower, but fail to lift	Down circuit open	Check down limit switch for malfunction
	Hoist overloaded	Reduce load to within rated capacity of hoist
	Considerable voltage drop	Applied voltage shall fall into $\pm 10\%$ of rated voltage on the name plate.
	Fault friction clutch	If abnormal operation or slippage occurs do not attempt to disassemble or adjust the friction clutch. Replace the malfunctioning friction clutch with a new or factory adjusted part.
	Malfunction of the Up contact of the pendant switch	Replace pendant switch
Short circuit	Melted B contact of pendant switch	Replace pendant switch
	Burnt diode	Replace diode and pay attention to its poles
	Burnt D type resistor	Replace resistor
	Having too much carbon powder on carbon brush holder	Disassembly the motor and clean carbon powder
	Burnt motor	Replace motor
Fail to lift the load rated	Hoist overloaded	Reduce load
	Considerable voltage drop	Applied voltage shall fall into $\pm 10\%$ of rated voltage on the name plate
	Incorrect carbon brush specification or too short	Replace carbon brush
	Burnt, deformation of carbon brush holder	Replace carbon brush holder
Load drifts excessively when hoist is stopped	The gap of ratchet brake is too large	Adjust the ratchet brake
	Malfunction of pressed spring of ratchet brake	Replace the pressed spring
Oil leakage	Improper installation of cap screw	Proper installation of cap screw
	Damaged or deformed oil packing	Replace oil packing
	Fail to install oil packing	Install oil packing

COMEUP

COMEUP INDUSTRIES INC.

No.139, Jiyeukeng Rd., Ruifang Dist., New Taipei City 22453, Taiwan

TEL:+886-2-24971788 FAX:+886-2-24971699

Email: info@comeup.com.tw

<http://www.comeupwinch.com>

PN 882086 Ver:07

Specifications subject to change without notice