

Introduction

► Feature

- Line pull: 6,804 kg / 15,000 lb single line (EN 14492-1 rating)
- Brake: Automatic, full load cone brake
- Clutch: Turn the T-handle for rapid wire rope payout
- Control: Handheld pendant switch powers the winch
- Recommended wire rope: * 14 mm x 22 m, 1,960 N/mm² grade with a minimum breaking strength of 137 KN required for EN 14492-1 rating

Installation

Before using the winch, make sure all electrical components have no corrosion or damaged; the environment should be clear and dry.

► Mounting

- Winch shall be mounted on a flat and hard surface.
- Winch should be mounted as closed to center and as horizontal as possible to the direction of the line pull.
- Wire rope shall be wound in an under-wound orientation only.
- Eight (8) M12 X 1.75 pitch 8.8 grade w/76 N-m torque setting (maximum) high tensile steel bolts must be used in order to sustain the loads imposed on the winch mounting.
- Two (2) M12 x 1.75 pitch 8.8 grade w/76 N-m torque setting (maximum) high tensile steel bolts must be used for fastening the roller fairlead into the mounting channel.
- It is always preferred to use both tie bars in the final installed configuration.

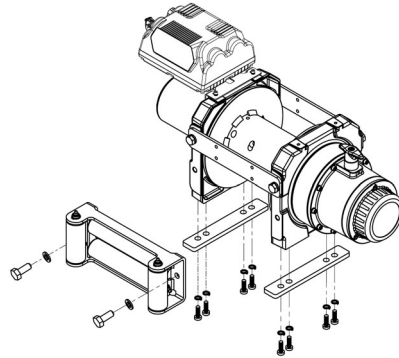

Compliance with EN 14492-1

The winch complies with European Standard of EN 14492:2006 Power-Driven Winches, CE Machinery Directive 2006/42/EC and CE EMC Directive 2004/108/EC provided that the OWNER or END USER complies with all responsibilities described below.

1. Refer to the Instruction Manual to install winch for safe winching operation.
2. Fit the recommended wire rope to comply with EN ratings:

- * Rope drives with steel wire rope shall be dimensioned
 - * At least 2:1 wire rope working coefficient for the first rope layer.
 - * At least 10:1 D/d ratio to the centre of the rope
 - * Drum freeboard shall be at least 1.5 x rope diameter.
3. The wire rope must be painted red for 1.6 m on both ends and at least five (5) wraps of wire rope remained around the drum to comply with EN ratings;
 - * At least two rope windings on the drum.
 - * Rope attachment to withstand 2.5 x the remaining static force.
 4. Fit an emergency stop switch to comply with emergency stop function.
 5. Fit a hook with a safety latch to comply with a safety hook.

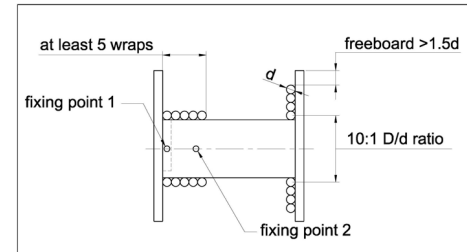

► Wiring Diagram

- Connect thermal sensor harness plug, control ground, and cable A/F1/F2 to the motor.
- Attach the ground lead firmly to the negative (-) battery terminal and power lead to the positive (+) battery terminal. The voltage drop for the winch motor must not exceed 10% of the nominal voltage of 24V DC.
- The over-load protector built in the control box shall be manually reset after reducing the load.
- **Always cover the socket with waterproof cap when not in use to prevent ingress of water or foreign objects.**
- **Installing ICB control box, it is necessary to install a fuse or battery isolation switch as additional protection.**

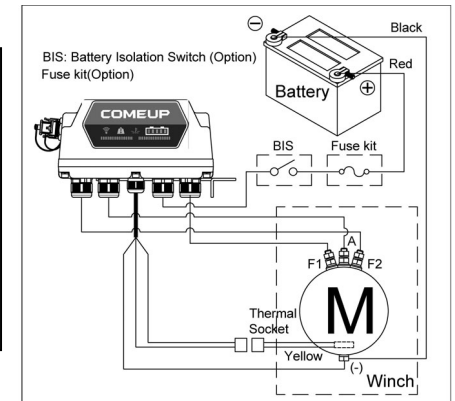
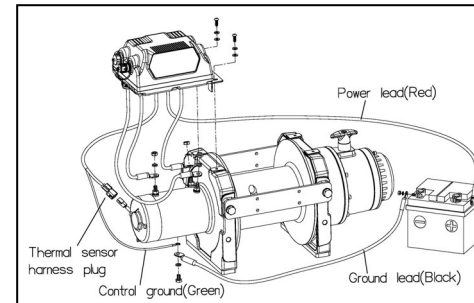

Warning

- The winch is not intended to be used in any manner for the movement or lifting of personnel.
- The rated line pull shown is based on the first layer of rope on the drum for the winch only, consult the wire rope manufacturer for wire rope rating.
- The rope winding on the drum shall remain 5 wraps from the drum.

Parts List

Item No.	Description	Part No.	Qty
1	Motor 24V	883448	1
2	Tie bar kit	883449	2
3	Motor support rack kit	883450	1
4	Motor coupling	880047	1
5	Drum bushing	880048	2
6	Drum kit	883451	1
7	Gearbox support rack	883452	1
8	Grounding lead	880009	1
9	1 st shaft	880053	1
10	3 rd ring gear kit	882436	1
11	3 rd stage carrier kit	881944	1
12	2 nd stage carrier kit	881943	1
13	1 st stage carrier kit	880107	1
14	C ring	880058	1
15	1 st & 2 nd ring gear	880059	1
16	1 st pinion kit	880060	1
17	Clutch kit	880061	1
18	Gear box kit	882437	1
19	Brake base	882438	1
20	Cone brake disc kit	880021	1
21	Brake cover kit	882423	1
22	Roller fairlead	882481	1
23	Mounting hardware	883453	1
24	Remote control	883509	1
25	Control box 24V	883521	1
26	Brake clutch base	881434	1

Winch Assembly

