

**Introduction**

► **Feature**

- Lifting capacity: 250 kg
- Lifting height: 3 m
- Line speed: 13.1 m/min
- Brushless DC motor output: 500w x 6.6A at 200-240V
- Brake: Dual brakes of double mechanical ratchet pawls and a motor dynamic brake
- Control: Pendant switch powers the hoist

► **Unpacking**

- Hoist assembly 1pc
- Load chain 6.3 mm x 3.5 m w/hook tackle 1pc
- Power lead 1.5 mm<sup>2</sup> x 3C x 3m w/3 round pins plug 1pc
- Pendant switch PB-418 w/cord 0.5 mm<sup>2</sup> x 7C x 3m 1pc

► **Read this manual carefully**

You should carefully read and understand this manual before operating it. Careless hoist operation may result in personal injury hazards or property damage.

► **Information requesting or parts ordering**

Please specify the followings information:

- Hoist PN
- Quantity for each part
- Part description
- Serial number
- Replacement part

**Installation**

Before using the hoist, make sure all electrical components have no corrosion or damaged; the environment should be clear and dry.

► **Load Chain Replacement**

- 1). Be sure that the replacement chain is the exact size, grade and constructions as the original chain. The new load chain must have an odd number links so that both its end links have the same orientation. Destroy the old chain to prevent its reuse.
- 2). When replacing load chain, check for wear on mating parts such as sprocket , and replace parts if necessary.
- 3). Remove all chain components including load hook kit from the old chain for reuse on new chain. Inspect and replace any damaged or worm parts.
- 4). Using a C-link to attach the new chain to the old end link on the no-load side. The new end link should be connected so the welded portion to pass over the sprocket.
- 5). Operate the hoist down to move the chain through the hoist body. Stop when a sufficient amount of new chain is accumulated on the load side.

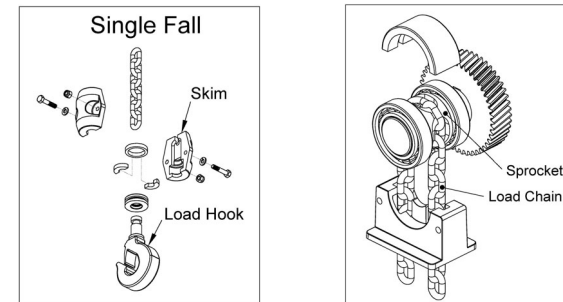

► **Wiring Diagram**

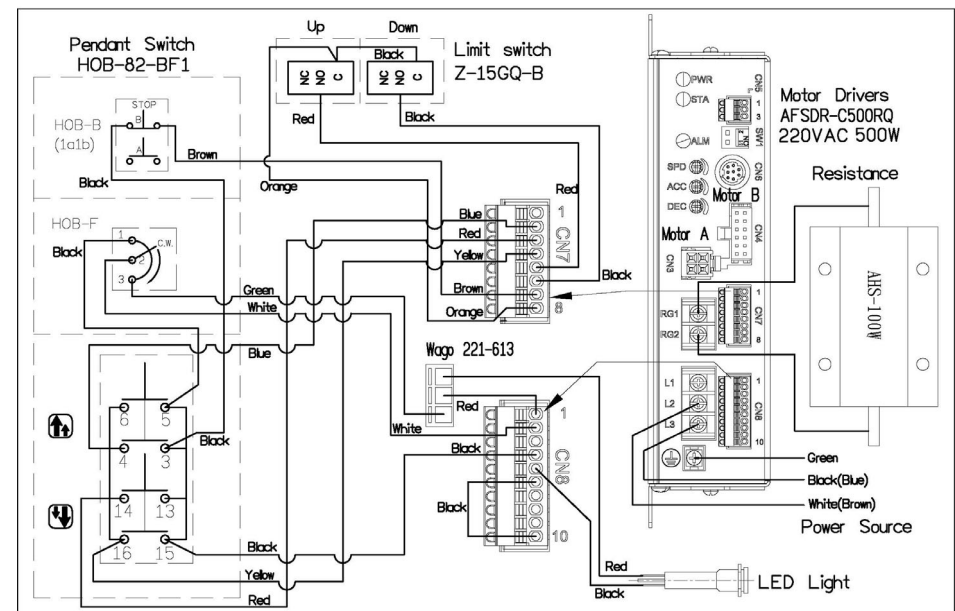

## Warning

- The hoist is not intended to be used in any manner for the movement or lifting of personnel.

## Parts List

Item No.	Description	Part No.	Qty
1	Gear box	884389	1
2	Brushless DC motor kit 200V~240V	884363	1
3	1 <sup>st</sup> pinion kit	884463	1
4	1 <sup>st</sup> gear kit	884464	1
5	Ratchet stopper kit	881794	2
6	Sprocket kit	881795	1
7	2 <sup>nd</sup> gear kit	881858	1
8	R-type retaining ring	881867	1
9	Sprocket protector kit	881796	1
10	Brake rear cover kit	881797	1
11	Hook suspension	881798	1
12	Head pin	881799	1
13	Gearbox rear cover kit	884364	1
14	Motor drivers 200V~240V	884365	1
15	Limit switch	884366	1
16	Electric cover kit	884367	1
17	Load chain 3.5 m	881801	1
18	Upper and down limit kits	884368	1
19	Chain bag kit	884369	1
20	Down hook kit	884372	1
21	Counter weight kit	884370	1
22	Cable gland AG-16	881809	1
23	Cable gland AG-20	881810	1
24	Power lead w/2 flat pins plug	884371	1
	Power lead w/3 round pins plug	884376	1
25	Remote control, PB-418	884360	1

## Hoist Assembly

