

PORTABLE HOIST

300/500/1,000 kg lifting load. 200-240V

EASYLIFT

- Permanent magnetic motor features constant output and low noise level.
- Lightweight and compact designs are ideal for easy installation.
- Dual brakes for mechanical ratchet pawls and a motor dynamic brake provide slip free operation.
- Power cutoff switch prevent the overloading of the hoist.
- Tough Steel Alloy die cast housing provides massive structural durability.
- Can operate on standard domestic power supply and equip with industrial plug
- A switch w/emergency stop comes as standard.
- A 360° top hook fitted with a self-locking latch is capable of swiveling with the safe working load applied.
- Standard Compliance: CE Machinery Directive 2006/42/EC, CE EMC Directive 2014/30/EU, CE LVD Directive 2014/35/EU.
- Unlimited lifting height, based on the length of the used wire rope.

SPECIFICATIONS

Model	EL-300	EL-500	EL-1000
Duty Cycle	10% ED with at 100% of rated load		
Motor Output	500W	800W	
Voltage	200~240V AC, single phase		
Lifting Load	300 kg	500 kg	1,000 kg
Gear Ratio	235.5 : 1		
Line Speed	6.0 m/min	4.8 m/min	2.4 m/min
Lifting Height	30 M		15 M
	Full capacity maximum continuous lifting		
Brake	Brakes for mechanical ratchet pawls and motor dynamic brake		
Wire Rope	Standard with A7x19, 6.3 mm x 15 M		
Switch Cord	10m with emergency stop		
Protection	Overload Protector (manual reset)		

DIMENSION mm/in

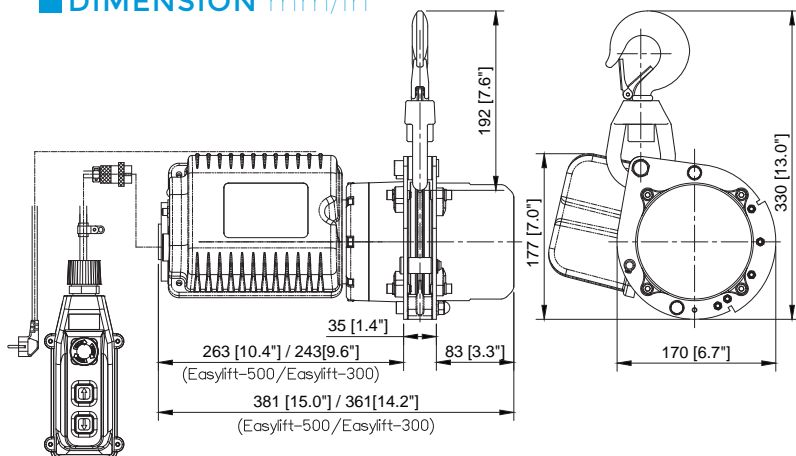

STANDARD ACCESSORIES

- Wire rope: 6.3 mm x 15 m
- Remote control w/emergency stop w/1.25 mm² x 6C x 10 m cord
- Industrial plug w/1.5 mm² x 3C x 3 m
- Hook: 5/16" Clevis Hook
- Double Rope (EL-1000)
- Tackle Block (EL-1000)

PACKAGE

- EL-300: Hoist weight : 16.4 kg
Gross weight : 24.9 kg
- EL-500: Hoist weight : 16.9 kg
Gross weight : 25.4 kg
- EL-1000: Hoist weight : 16.9 kg
Gross weight : 36.7 kg
- Box dimension: 505 x 244 x 403 mm

Warning

- The hoist is not intended to be used in any manner for the movement or lifting of personnel.
- The fixing point for portable hoist shall be capable of supporting the load required.

Warranty

Each new hoist is guaranteed against defects in workmanship and material defects for a period of twelve months from date of purchase. Wire rope is not included underwarranty.