

Compact Strap Hoist

130 / 250 kg lifting load



Features Include

- Light Weight and Compact Design. Allow easy installation.
- High Strength Strap offers smoother winding. Eliminates load rotation problem with wire rope or chain. Straps do not chip or spark.
- Equipped with upper limit switch to prevent over lifting.
- Suitable for work place requires stricter levels of cleanliness.
- Triple brakes design provide slip free operation.
- Permanent magnetic motor features constant output and low noise level.
- Can operate on standard domestic power supply and equip with industrial plug.
- Standard Compliance (220V) : CE Machinery Directive 2006/42/EC, CE EMC Directive 2014/30/EU, Safety of machinery EN 60204-32:2008

Specifications

Model	CSH-130	CSH-250
Duty Cycle	25% ED, 63% Load	
Motor Output	300W	
Voltage	100 ~ 120V AC, 1 ph / 200 ~ 240V AC, 1 ph	
Lifting Load	130 kg	250 kg
Gear Ratio	112.7 : 1	216 : 1
Line Speed	9 - 12 m/min	5 - 6 m/min
Lifting Height	5 m	
Brake	Spring applied drag brake + Disk Drag brake + Motor Dynamic brake	
Drum	90 x 140 x 53 mm	
Strap	50 mm x 1.2 mm x 5.5 M (breaking strength 1,500 kg)	
Control	5M (Emergency Stop Button)	
Protection	Upper Limit Switch	

Dimension mm/in

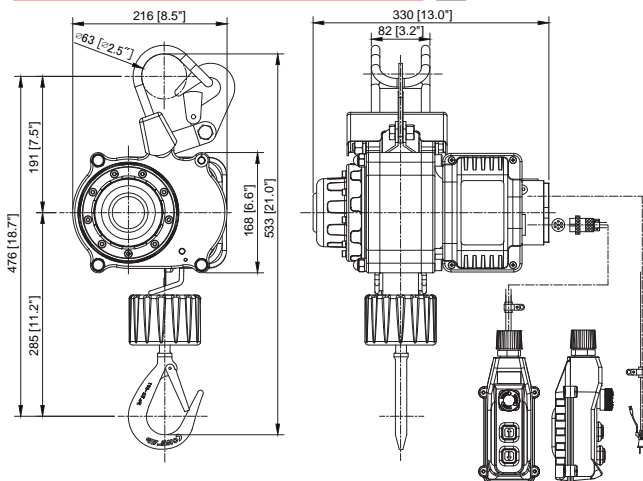

Standard Accessories

- Strap
- Remote control w/emergency stop w/cord : 1.25 mm² x 6C x 5 m
- Industrial plug : 1.5 mm² x 3C x 3 m
- Weight hook
- Hook

Warning

- The hoist is not intended to be used in any manner for the movement or lifting of personnel.
- The strap winding on the drum shall remain 3 wraps on the drum and must not be used to sure safe operation.
- Strap may break under unnoticed conditions. Operate the strap hoist away from the strap operating area and perform regular maintenance.

Warranty

Each new hoist is guaranteed against defects in workmanship and material defects for a period of twelve months from date of purchase. Strap are not included under warranty.

Package

- Hoist weight : 16 kg
- Gross weight : 20.5 kg
- Box dimension : 453 x 329 x 355 mm

