



# Electric Winch

## Model: CWG-30075

PN : 151455 415V50Hz  
153855 380V50Hz

### Introduction

#### ► Feature

- Lifting capacity: 300 kg wire rope top layer
- Lifting height: 29 m
- Lifting speed: 10-15 m/min at 50Hz
- Brake: Electromagnetic spring-applied failsafe brake
- Control: Pendant switch powers the winch

#### ► Unpacking

- Winch assembly 1pc
- Wire rope 6 mm x 30 m 1pc
- Weight hook CHW-0031 1pc
- Low voltage control ass'y LV-320 1pc
- Pendant switch PB-306 w/cord 1.25 mm<sup>2</sup> x 3C x 3 m 1pc

#### ► Read this manual carefully

You should carefully read and understand this manual before operating it. Careless winch operation may result in personal injury hazards or property damage.

#### ► Information requesting or parts ordering

Please specify the followings information:

- Winch PN
- Serial number
- Part description
- Replacement part number
- Quantity for each part

### Installation

Before using the winch, make sure all electrical components have no corrosion or damaged; the environment should be clear and dry.

#### ► Performance

Winch Model				CWG-30075							
Motor	kw x p			0.75 x 4							
Recommend Wire Rope	Size (mm)			6							
	Breaking (kg)			2,010							
1 <sup>st</sup> Layer	Rated Load (kg)	50Hz	444	2 <sup>nd</sup> Layer	Rated Load (kg)	50Hz	396	3 <sup>rd</sup> Layer	Rated Load (kg)	50Hz	358
	Speed (m/min)	50Hz	10.0		Speed (m/min)	50Hz	11.4		Speed (m/min)	50Hz	12.5
	Rope-Winding Cumulating Sum (m)				5.4	Rope-Winding Cumulating Sum (m)			11.5	Rope-Winding Cumulating Sum (m)	
4 <sup>th</sup> Layer	Rated Load (kg)	50Hz	326	5 <sup>th</sup> Layer	Rated Load (kg)	50Hz	300				
	Speed (m/min)	50Hz	13.8		Speed (m/min)	50Hz	15.0				
	Rope-Winding Cumulating Sum (m)				25.7	Rope-Winding Cumulating Sum (m)			30		

#### ► Wiring Diagram

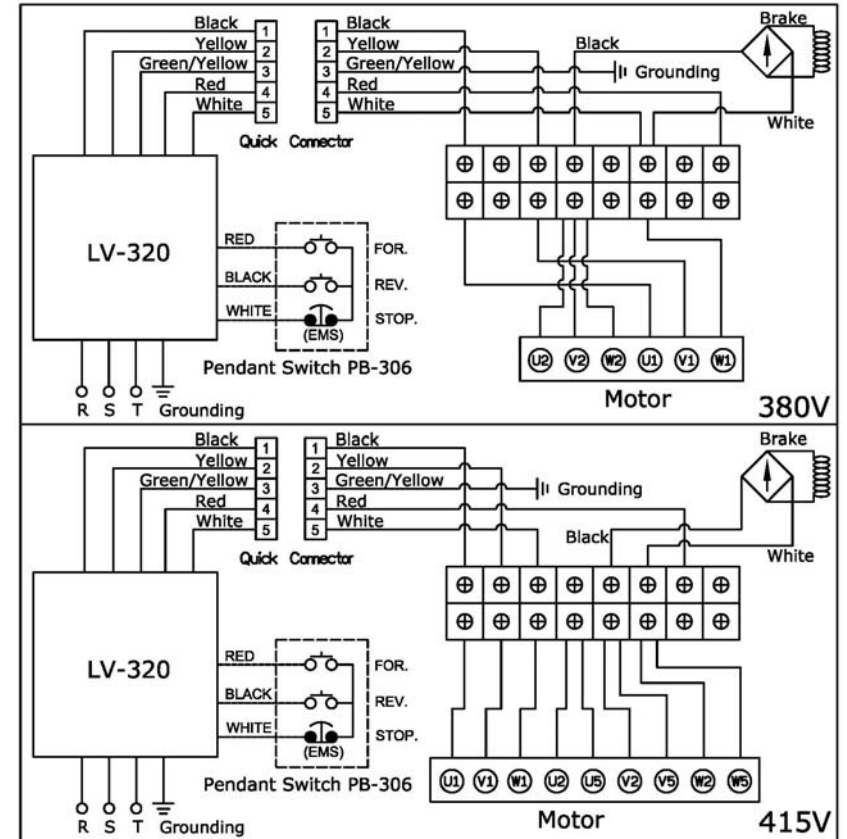

## Warning

- The winch is not intended to be used in any manner for the movement or lifting of personnel.
- The lifting capacity shown is based on the top layer of rope on the drum.
- The rope winding on the drum shall remain 5 wraps from the drum.

## Parts List

Item No.	Description	Part No.	Qty
1	Induction motor kit 380V	881689	1
	Induction motor kit 415V	881690	
2	Low voltage control ass'y LV-320 for 380V	882178	1
	Low voltage control ass'y LV-320 for 415V	881695	
2-1	Remote control, PB-306	881048	1
3	Bridge rectifier	880368	1
4	Support bracket	880369	2
5	Drum kit	880370	1
6-1	Tie bar	881862	1
6-2	Tie bar kit	880371	3
7	2 <sup>nd</sup> shaft kit	880372	1
8	Gear box kit	880373	1
9	1 <sup>st</sup> stage carrier	880374	1
10	1 <sup>st</sup> shaft kit	880375	1
11	Conductor kit	880376	1
12	Brake coil	880388	1
13	Conductor plate A	880403	2
14	Brake disc	880379	2
15	Hex socket	880380	1
16	Conductor plate B kit	880381	1
17	Brake cover	880382	1
18	Wire rope	880383	1
19	Weight hook CHW-0031	880384	1

## Winch Assembly

