



Electric Winch

Model: **CWG-30075**

PN : 150583 380V50Hz 153400 400V50Hz
154155 415V50Hz
931075 380V60Hz

Introduction

► Feature

- Lifting capacity: 300 kg wire rope top layer
- Lifting height: 29 m
- Lifting speed: 10-15 m/min at 50Hz ; 12-18m/min at 60Hz
- Brake: Electromagnetic spring-applied failsafe brake
- Control: Pendant switch powers the winch

► Unpacking

- Winch assembly 1pc
- Wire rope 6 mm x 30 m 1pc
- Weight hook CHW-0031 1pc
- Pendant switch PB-331 w/cord 2.0 mm² x 5C x 3 m 1pc

► Read this manual carefully

You should carefully read and understand this manual before operating it. Careless winch operation may result in personal injury hazards or property damage.

► Information requesting or parts ordering

Please specify the followings information:

- Winch PN
- Serial number
- Part description
- Replacement part number
- Quantity for each part

Installation

Before using the winch, make sure all electrical components have no corrosion or damaged; the environment should be clear and dry.

► Performance

Winch Model				CWG-30075							
Motor	kw x p	0.75 x 4									
Recommend Wire Rope	Size (mm)	6									
	Breaking (kg)	2,010									
1 st Layer	Rated Load (kg)	50Hz	444	2 nd Layer	Rated Load (kg)	50Hz	396	3 rd Layer	Rated Load (kg)	50Hz	358
		60Hz	444			60Hz	396			60Hz	358
	Speed (m/min)	50Hz	10.0			50Hz	11.4			50Hz	12.5
		60Hz	12.0		60Hz	13.7		60Hz	15		
	Rope-Winding Cumulating Sum (m)	5.4			Rope-Winding Cumulating Sum (m)	11.5			Rope-Winding Cumulating Sum (m)	18.3	
4 th Layer	Rated Load (kg)	50Hz	326	5 th Layer	Rated Load (kg)	50Hz	300				
		60Hz	326			60Hz	300				
	Speed (m/min)	50Hz	13.8			50Hz	15.0				
		60Hz	16.7		60Hz	18.0					
	Rope-Winding Cumulating Sum (m)	25.7			Rope-Winding Cumulating Sum (m)	30					

► Wiring Diagram

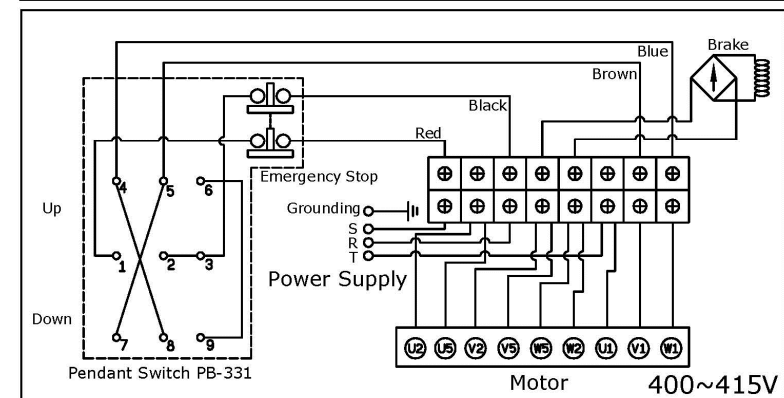
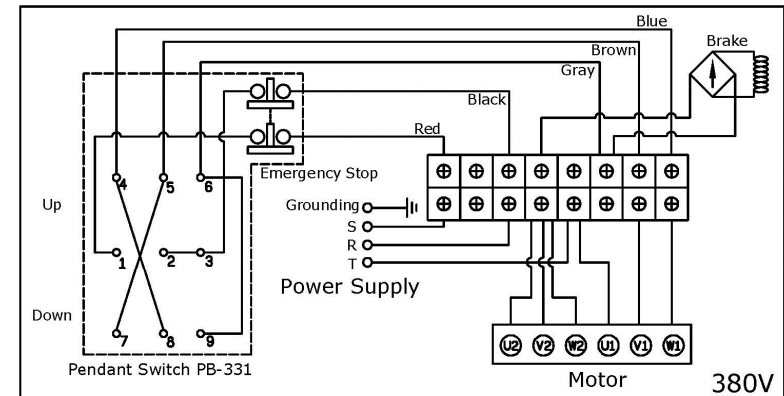

Warning

- The winch is not intended to be used in any manner for the movement or lifting of personnel.
- The lifting capacity shown is based on the top layer of rope on the drum.
- The rope winding on the drum shall remain 5 wraps from the drum.

Parts List

Item No.	Description	Part No.	Qty
1	Induction motor kit , 380V 50Hz	881689	1
	Induction motor kit , 380V 60Hz	880852	
	Induction motor kit , 400/415V	881690	
2	Control kit, PB-331	881968	1
3	Bridge rectifier	880368	1
4	Support bracket	880369	2
5	Drum kit	880370	1
6-1	Tie bar	881862	1
6-2	Tie bar kit	880371	3
7	2 nd shaft kit	880372	1
8	Gear box kit	880373	1
9	1 st stage carrier	880374	1
10	1 st shaft kit	880375	1
11	Conductor kit	880376	1
12	Brake coil	880388	1
13	Conductor plate A	880403	2
14	Brake disc	880379	2
15	Hex socket	880380	1
16	Conductor plate B kit	880381	1
17	Brake cover	880382	1
18	Wire rope	880383	1
19	Weight hook CHW-0031	880384	1

Winch Assembly

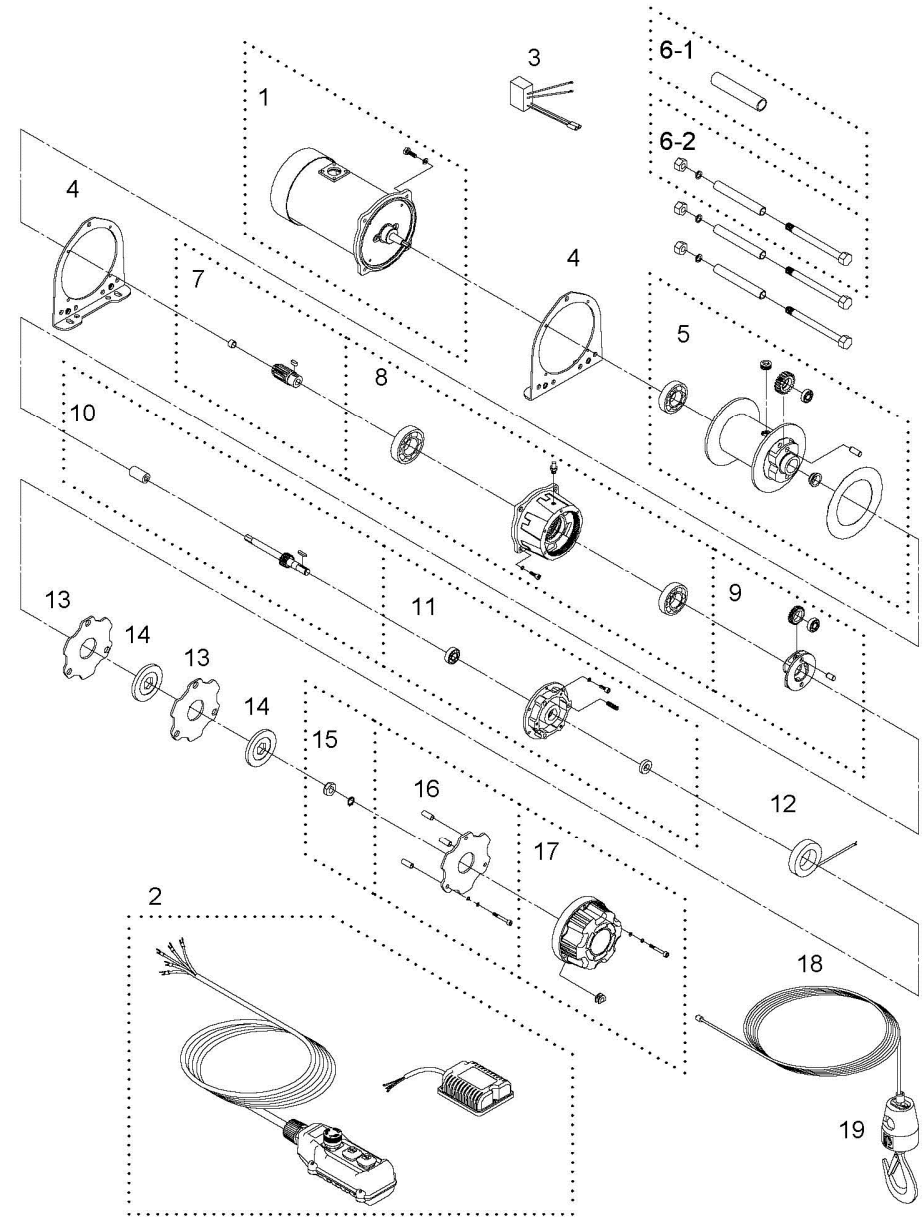

Ver:2