



Electric Winch

Model: CP-500T

PN: 155002 380V50Hz
155125 415V50Hz

Introduction

► Feature

- Lifting capacity: 500 kg at wire rope top layer
- Lifting height: 58 m
- Lifting speed: 12~18 m/min at 50Hz
- Brake: Electromagnetic spring-applied failsafe brake
- Control: Pendant switch powers the winch

► Unpacking

- Winch assembly 1pc
- Wire rope 7 mm x 60 m 1pc
- Weight hook CHW-0005 1pc
- Low voltage control ass'y LV-320 1pc
- Pendant switch PB-306 w/cord 1.25 mm² x 3C x 3 m 1pc

► Read this manual carefully

You should carefully read and understand this manual before operating it. Careless winch operation may result in personal injury hazards or property damage.

► Information requesting or parts ordering

Please specify the followings information:

- Winch PN
- Part description
- Replacement part number
- Serial number
- Quantity for each part

Installation

Before using the winch, make sure all electrical components have no corrosion or damaged; the environment should be clear and dry.

► Performance

Winch Model		CP-500T									
Motor	kw x p	1.8 x 4									
Recommend Wire Rope	Size (mm)	7									
	Breaking (kg)	2,700									
1 st Layer	Rated Load (kg)	50Hz	757	2 nd Layer	Rated Load (kg)	50Hz	671	3 rd Layer	Rated Load (kg)	50Hz	602
	Speed (m/min)	50Hz	12		Speed (m/min)	50Hz	13.4		Speed (M/min)	50Hz	14.9
	Rope-Winding Cumulating Sum (m)	10			Rope-Winding Cumulating Sum (m)	22			Rope-Winding Cumulating Sum (m)	35	
4 th Layer	Rated Load (kg)	50Hz	546	5 th Layer	Rated Load (kg)	50Hz	500				
	Speed (m/min)	50Hz	16.4		Speed (m/min)	50Hz	18				
	Rope-Winding Cumulating Sum (m)	50			Rope-Winding Cumulating Sum (m)	60					

► Wiring Diagram

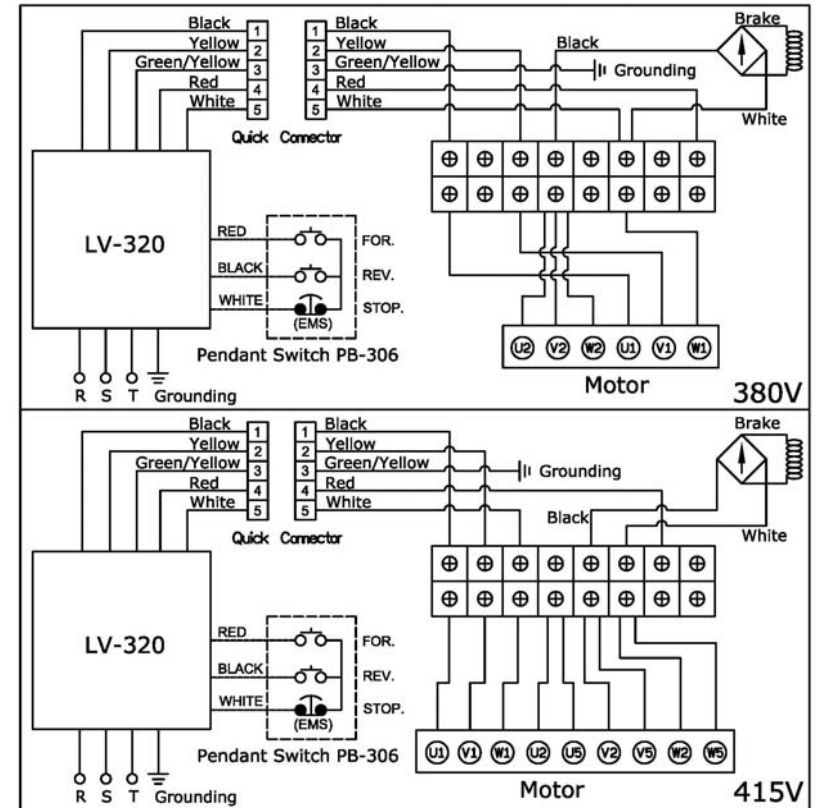

Warning

- The winch is not intended to be used in any manner for the movement or lifting of personnel.
- The lifting capacity shown is based on the top layer of rope on the drum.
- The rope winding on the drum shall remain 5 wraps from the drum.

Parts List

Item No.	Description	Part No	Qty
1	Induction motor kit 380V	880459	1
	Induction motor kit 415V	880460	
2	Low voltage control ass'y LV-320,380V	881841	1
	Low voltage control ass'y LV-320,415V	881840	
2-1	Remote control , PB-306	881048	1
3	Bridge rectifier CBR-072	880425	1
4	Support bracket	880426	2
5	Drum kit	880427	1
6-1	Tie bar	880428	1
6-2	Tie bar kit	880429	2
6-3	Tie bar kit	880430	2
7	2 nd shaft kit	880431	1
8	Gear box kit	880432	1
9	1 st stage carrier	881301	1
10	1 st shaft kit	881302	1
11	Conductor kit	880435	1
12	Brake coil	880436	1
13	Conductor plate A	880438	2
14	Brake disc	880379	2
15	Hex socket	880440	1
16	Conductor plate A kit	880437	1
17	Brake cover	880442	1
18	Wire rope w/weight hook	880443	1

Winch Assembly

