



Electric Winch

Model: CP-500

PN: 155120 220V50Hz 155123 230V50Hz 931330 220V60Hz
 155119 220V60Hz 157600 220V60Hz 152123 240V50Hz
 157610 220V60Hz 153025 230V60Hz

Introduction

► Feature

- Lifting capacity: 500 kg wire rope top layer
- Lifting height: 58 m
- Lifting speed: 10~15 m/min at 50Hz ; 12~18 m/min at 60Hz
- Brake: Electromagnetic spring-applied failsafe brake
- Control: Pendant switch powers the winch

► Unpacking

- Winch assembly 1pc
- Wire rope 7 mm x 60 m 1pc
- Weight hook CHW-0005 1pc
- Pendant switch w/cord 3.5 mm² x 5C x 6 m 1pc

► Read this manual carefully

You should carefully read and understand this manual before operating it. Careless winch operation may result in personal injury hazards or property damage.

► Information requesting or parts ordering

Please specify the followings information:

- Winch PN
- Serial number
- Part description
- Replacement part number
- Quantity for each part

Installation

Before using the winch, make sure all electrical components have no corrosion or damaged; the environment should be clear and dry.

► Performance

Winch Model		CP-500											
Motor	kw x p	1.8 x 4											
Recommend Wire Rope	Size (mm)	7											
	Breaking (kg)	2,700											
1 st Layer	Rated Load (kg)	50Hz	757	2 nd Layer	Rated Load (kg)	50Hz	671	3 rd Layer	Rated Load (kg)	50Hz	602		
		60Hz	757			60Hz	671			60Hz	602		
	Speed (m/min)	50Hz	10			Speed (m/min)	50Hz		11.6		Speed (m/min)	50Hz	12.9
		60Hz	12			60Hz	13.8			60Hz	15.4		
	Rope-Winding Cumulating Sum (m)	10			Rope-Winding Cumulating Sum (m)	22			Rope-Winding Cumulating Sum (m)	35			
4 th Layer	Rated Load (kg)	50Hz	546	5 th Layer	Rated Load (kg)	50Hz	500						
		60Hz	546			60Hz	500						
	Speed (m/min)	50Hz	14.2			Speed (m/min)	50Hz	15					
		60Hz	17			60Hz	18						
	Rope-Winding Cumulating Sum (m)	50			Rope-Winding Cumulating Sum (m)	60							

► Wiring Diagram

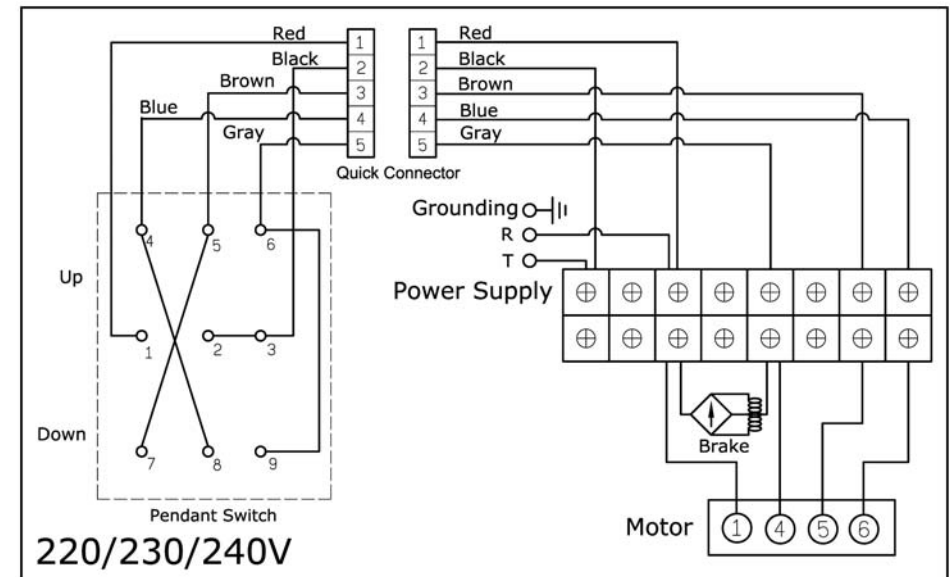

Warning

- The winch is not intended to be used in any manner for the movement or lifting of personnel.
- The lifting capacity shown is based on the top layer of rope on the drum.
- The rope winding on the drum shall remain 5 wraps from the drum.

Parts List

Item No.	Description	Part No.	Qty
1	Induction motor kit,220V/50Hz	880452	1
	Induction motor kit,220V/60Hz, PN:931330	880451	
	Induction motor kit,220V/60Hz	881552	
	Induction motor kit,240V/50Hz	880453	
	Induction motor kit,230V/50Hz	882544	
2	Control box	880424	1
	Control box, PN:157600	882064	1
3	Bridge rectifier CBR-072	880425	1
4	Support bracket	880426	2
5	Drum kit	880427	1
6-1	Tie bar	880428	1
6-2	Tie bar kit	880429	2
6-3	Tie bar kit	880430	2
7	2 nd shaft kit	880431	1
8	Gear box kit	880432	1
9	1 st stage carrier	880433	1
10	1 st shaft kit	880434	1
11	Conductor kit	880435	1
12	Brake coil	880436	1
13	Conductor plate A	880438	2
14	Brake disc	880379	2
15	Hex socket	880440	1
16	Conductor plate A kit	880437	1
17	Brake cover	880442	1
18	Wire rope w/weight hook	880443	1
19	Remote control	880387	1
	Remote control, PN:157600	882065	1

Winch Assembly

