

**Introduction**

► **Feature**

- Lifting capacity-top layer: 250 kg
- Lifting height: 5M
- Lifting speed: 5 - 6 m/min
- Brake: Spring applied drag brake + Disk Drag brake + Motor Dynamic brake
- Limit protection: Lifting limiters
- Control: Pendant switch powers the hoist

► **Unpacking**

- Hoist assembly 1pc
- Strap 50 mm x 1.2 mm x 5.5 M 1pc
- Weight hook CHW-0044 1pc
- Power lead 2.0 mm<sup>2</sup> x 3C x 3 m and plug for PN:472500 1pc
- Power lead 1.5 mm<sup>2</sup> x 3C x 3 m and plug for PN:472520 1pc
- Power lead 2.0 mm<sup>2</sup> x 3C x 3 m and plug for PN:472610 1pc
- Pendant switch PB-417 w/cord 1.25 mm<sup>2</sup> x 6C x 5 m 1pc

► **Read this manual carefully**

You should carefully read and understand this manual before operating it. Careless hoist operation may result in personal injury hazards or property damage.

► **Information requesting or parts ordering**

Please specify the followings information:

- Hoist PN
- Serial number
- Part description
- Replacement part number
- Quantity for each part

**Installation**

Before using the hoist, make sure all electrical components have no corrosion or damaged; the environment should be clear and dry.

► **Strap replacement**

- Tighten the strap on the drum with 2 piece of set screw M5 x 20L.
- Put a strap through the hole of the safety stopper.
- Insert a sleeve pin through the thimble of strap.
- Insert a pin through the sleeve pin and bent it by pliers.

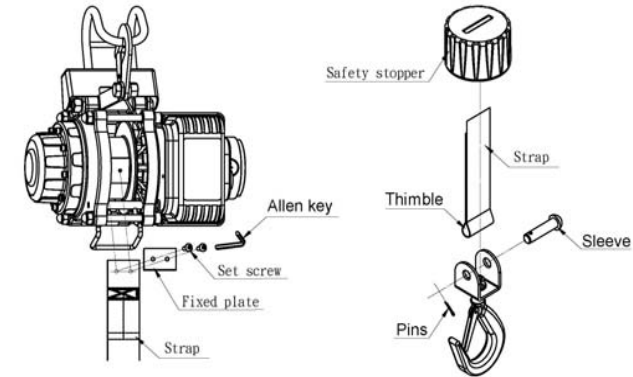

► **Wiring Diagram**

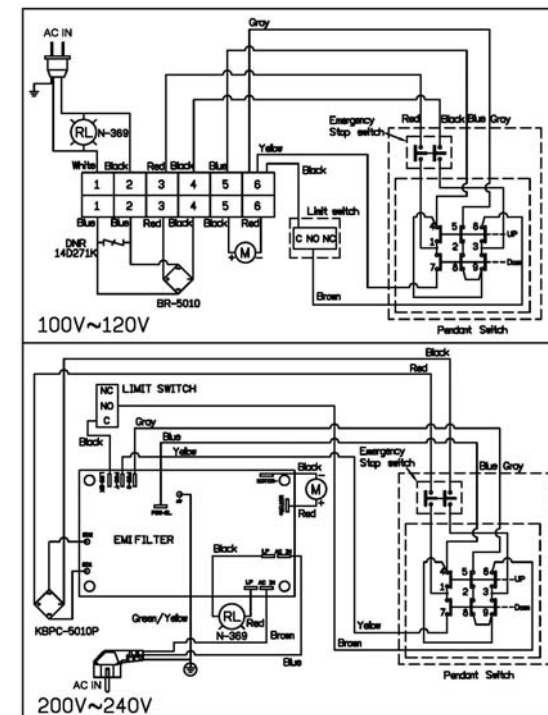

## Warning

- The hoist is not intended to be used in any manner for the movement or lifting of personnel.
- The strap winding on the drum shall remain 3 wraps on the drum and must not be used to ensure safe operation.
- Strap may break under unnoticed conditions. Operate the strap hoist away from the strap operating area and perform regular maintenance.

## Part List

Item No.	Description	Part No.	Qty
1	Motor kit 100~120V	883553	1
	Motor kit 200~240V	883625	
2	Motor support rack	883554	1
3	Motor couple kit	880988	1
4	Drum bushing	883555	1
5	Drum kit	883556	1
6	Gearbox support rack	883557	1
7	Strap	883558	1
8	Weight hook w/safety stopper	883559	1
9	Cover kit	883560	1
10	1 <sup>st</sup> shaft kit	883561	1
11	3 <sup>rd</sup> ring gear kit	883563	1
12	2 <sup>nd</sup> stage carrier	883564	1
13	1 <sup>st</sup> stage carrier	883566	1
14	Brake kit	883568	1
15	Gear box kit	883569	1
16	Hanger kit	883570	1
17	Over-winding bracket kit	883571	1
18	Terminal upper cover kit	883572	1
19	Control panel,AC110V	883573	1
	Control panel,AC220V	883626	
20	Remote control, PB-417	883574	1
21	Power lead w/2 flat pins plug for PN:472500	883876	1
	Power lead w/2 flat pins plug for PN:472610	883879	
	Power lead w/2 round pins plug for PN:472520	883877	

## Hoist Assembly

