

Compact Winch Model: CWS-300

PN: 422013 220V
422138 230V

Introduction

► Feature

- Lifting capacity: 300 kg wire rope top layer
- Lifting height: 24 m
- Lifting speed: 9 – 13 m/min
- Brake: Electromagnetic and mechanical ratchet
- Limit protection: Lifting and lowering limiters
- Control: Pendant switch powers the winch

► Unpacking

- Winch assembly 1pc
- Wire rope 4.8 mm x 25 m (A7X19) 1pc
- Weight hook CHW-0033 1pc
- Power lead 1.5 mm² x 3C x 5 m and plug 1pc
- Pendant switch CPB-313 w/cord 1.25 mm² x 6C x 10 m 1pc

► Read this manual carefully

You should carefully read and understand this manual before operating it. Careless winch operation may result in personal injury hazards or property damage.

► Information requesting or parts ordering

Please specify the followings information:

- Winch PN
- Serial number
- Part description
- Replacement part number
- Quantity for each part

Installation

Before using the winch, make sure all electrical components have no corrosion or damaged; the environment should be clear and dry.

► Wire rope replacement

- Put a new wire rope through the hole of the round plate of swivel hook.
- Insert a sleeve pin through the thimble of wire rope.
- Insert a pin through the sleeve pin and bent it by a pliers.
- Let a new wire rope w/clamp through the limit lever and insert it into the hole of the drum.
- Put a P.T. screw into the hole of the drum and tighten it by a hexagon wrench.
- Press the ↑ button to rotate the drum in the lifting direction.
- An uneven winding of wire rope may cause the load to be swing, thus damaging the rope and reducing its life.

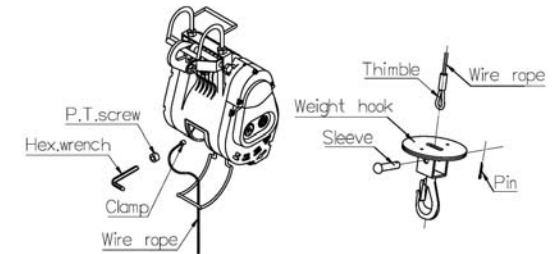

► Wiring Diagram

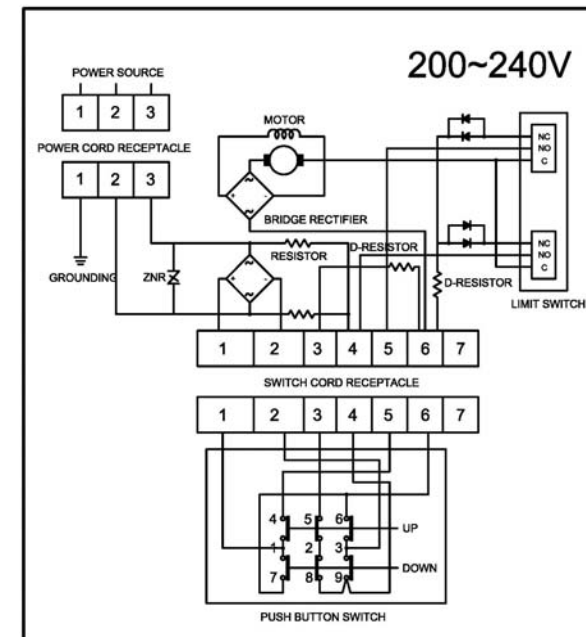

Warning

- The winch is not intended to be used in any manner for the movement or lifting of personnel.
- The lifting capacity shown is based on the top layer of rope on the drum.
- The rope winding on the drum shall remain 5 wraps from the drum.

Parts List

Item No.	Description	Part No.	Qty
1	Gearbox rear cover kit	880493	1
2	Ratchet stopper kit	880547	1
3	Brake kit	881507	1
4	1 st gear kit	881498	1
5	3 rd gear kit	881508	1
6	4 th gear kit	880500	1
7	Gear box kit	880470	1
8	Hanger kit	880476	1
9	Carbon brush holder	880472	1
10	Carbon brush 220/230/240V	880563	2
11	Over-winding bracket kit	880503	1
12	Wire rope	881244	1
13	Weight hook CHW-0033	880505	1
14	Armature core 220/230V	880976	1
15	Cooling cover	881500	1
16	Armature winding 220/230V	880518	1
17	Motor rear cover kit	880477	1
18	Reverse winding shaft kit	880478	1
19	Output shaft kit	880507	1
20	Drum kit	881575	1
21	Control panel 220~240V	881255	1
21-1	D type resistor 220~240V	883328	1
21-2	Limit switch	881503	2
21-3	Diode	881504	2
21-4	D type resistor 220~240V	883329	1
22	Rubber packing	880483	1
23	Electric cover kit	880511	1
24	Power lead w/3 round pins plug	880492	1
25	Remote control, CPB-313	880486	1

Winch Assembly

